

# hyperMILL®

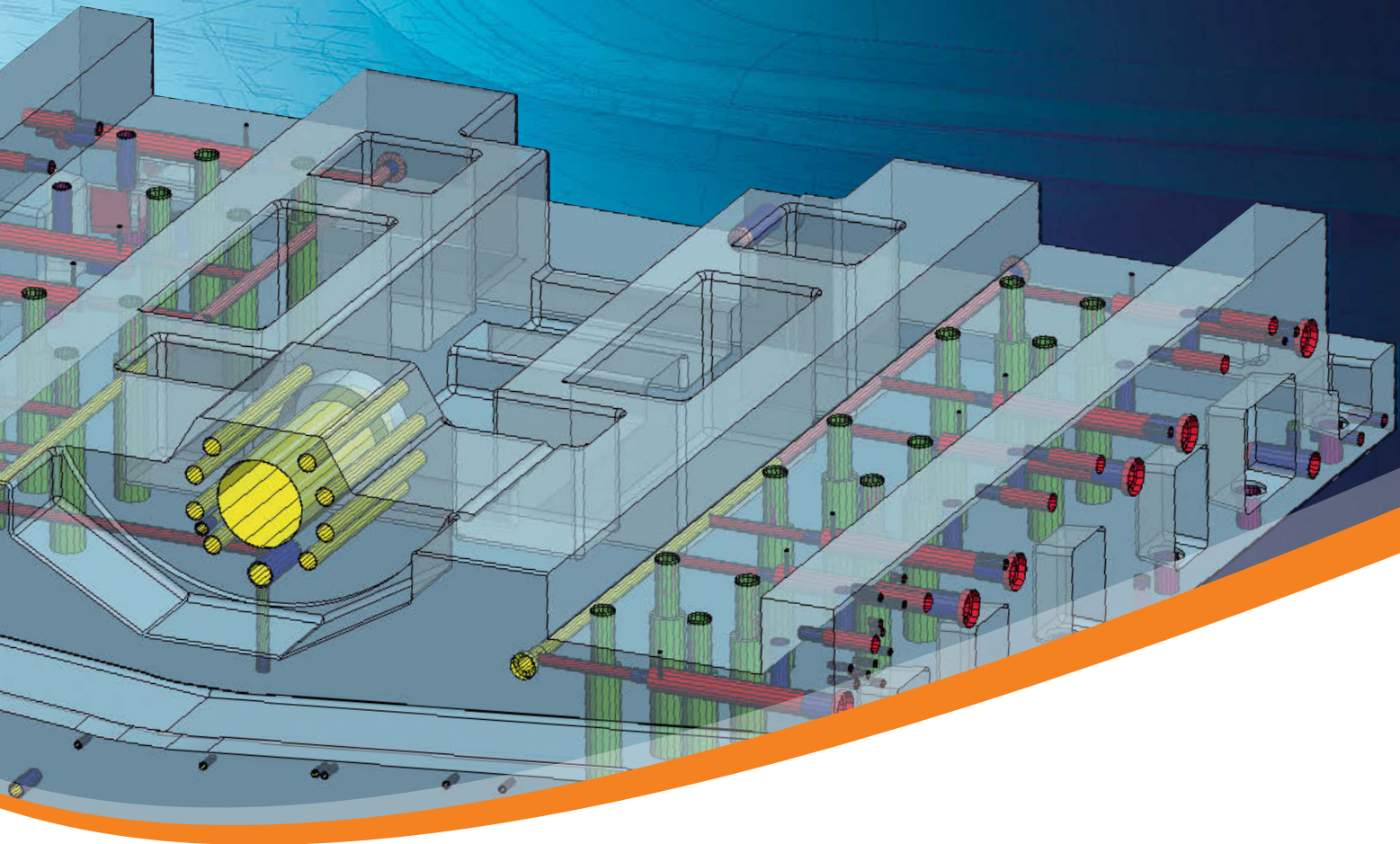

**Automated programming –  
efficient production**

PRODUCTION  
MACHINING

 **OPEN MIND**  
THE CAM FORCE



## High-performance CAM software for production environments

*hyperMILL*® is an intelligent CAM software solution designed for fast and efficient production machining. *hyperMILL*® provides an extensive selection of CAM strategies with the utmost production flexibility, ranging from the software's renowned 2D and 3D machining strategies to multi-axis indexing to mill/turn strategies and 5-axis machining. Programming is based on geometry features and a database for storing operations and job sequences. Many of the individual programming tasks can be automated, and many others can be programmed very quickly.

**Process reliability:** Integrated collision checking guarantees a workflow with maximum process reliability, analysing the machine, tool, part and fixture geometry. In addition to the machining simulation (with integrated collision check), the software provides a machine and material removal that lets you monitor the machining workspace. This simulation detects if any limit switches are traversed and helps to avoid unnecessary setup downtime and multiple setups.

**Efficiency:** Optimised tool-paths and rapid traverse movements contribute significantly to reduced machining times. OPEN MIND's Job List and Tool Database assist you creating complex structured programs and sequences.

**High-performance:** The *hyperMILL*® CAM concept is fully complemented by OPEN MIND's intelligent postprocessor technology. This ensures that the machine and controller logic – such as program part repetitions – can be applied with maximum efficiency in production.

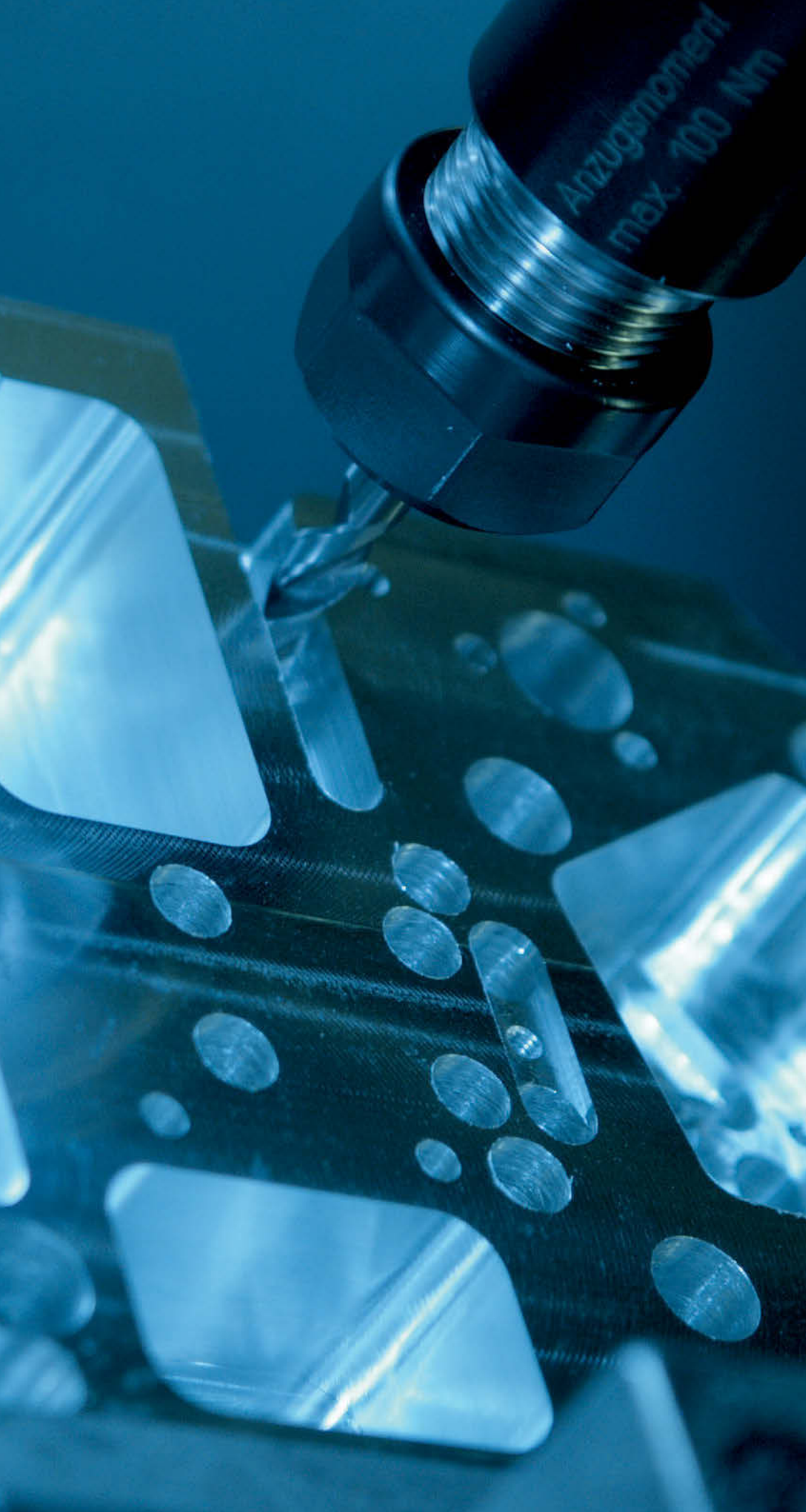

Face milling, contour milling, pocket machining and a wide range of drilling strategies mean that all the typical production tasks can be programmed quickly and machined efficiently.

*hyperMILL*® offers a diverse range of machining options for drilling operations. These include centering; simple drilling; drilling with pecking; drilling with chip break; reaming and boring; thread milling and drilling; deep hole drilling.

Our innovative 5-axis technology with automatic collision checking/avoidance ensures multi-axis indexing programs with maximum process reliability – ranging from reducing multiple set-ups to our unique multi-axis drilling strategies with synchronized and interference-checked tool paths connecting sequential holes.

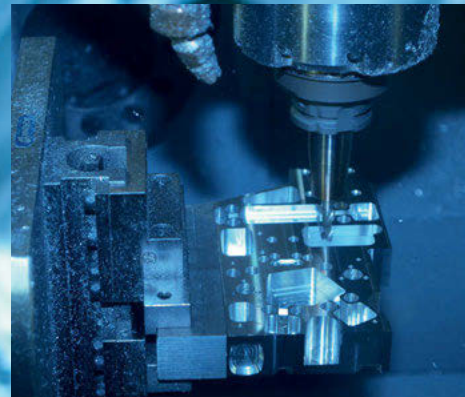



„When a part requires more than a hundred drilling steps, the job sequence has to be programmed very carefully. *hyperMILL*<sup>®</sup>'s tool database, feature programming, job list and stock management are exactly what we need for an efficient, fast and structured workflow.“

**Paul Amann, Head of CAM Programming and EDP at Ulmer Maschinenteile GmbH**

## Success through structured NC programs

Ulmer Maschinenteile GmbH produces parts in batches of 10-12 per production run. 90 percent of the machining jobs are performed on large-size parts. The cast parts are primarily machined using drilling, pocket machining, face milling and contour milling strategies. In this plant, the art of efficient machining rests almost entirely in the job preparation.

One of the company's biggest priorities in machining is process reliability, as the machines' tool magazines frequently hold up to 360 tools. All of the tools are managed via the OPEN MIND Tool Database.

The company's technicians programme all the required operations themselves using OPEN MIND's *hyperCAD*<sup>®</sup> solution. If any model data needs to be imported, this is done via *hyperCAD*<sup>®</sup>'s standardised STEP interface. The STEP interface detects both drilling features and threads, so the programming required

for drilling and pocket jobs can largely be automated using the software's feature recognition functionality.

Another crucial element in the company's highly structured workflow is the *hyperMILL*<sup>®</sup> Job List. This enables a transparent job overview with easy-to-understand programs. Together, the OPEN MIND solutions facilitate a very efficient workflow, ranging from CAM programming and tool management right up to the actual machining.

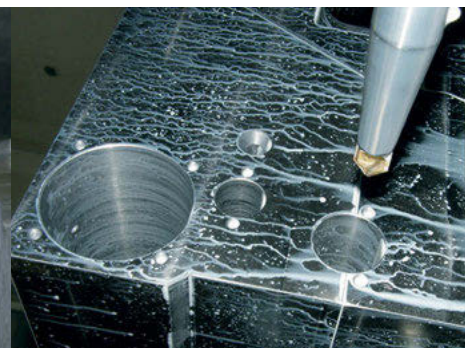
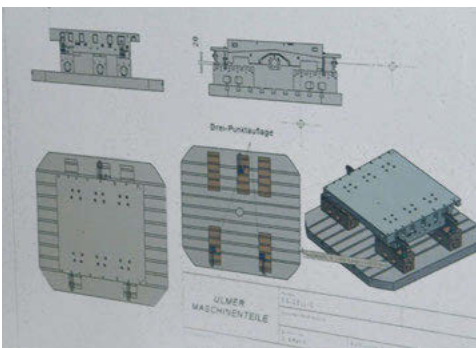



Job planning is at the heart of production at Ulmer Maschinenteile GmbH. As a result of careful job planning, the plant's machining programs can be run on multiple machines with identical tools. This is possible thanks to systematic and detailed entries for all the available tools in the OPEN MIND Tool Database. The tool data is imported via a standardized interface and formatted according to a predefined template. This guarantees that identical tools are used for machining on the different machines. In addition, the tool database ensures maximum process reliability for all the defined tools.



## Transparent planning and continuous processes

2D machining jobs may look simple – but parts with a hundred or more drillings require meticulous planning and job preparation. OPEN MIND's *hyperMILL*® CAM software offers just the right functions and tools for this. With *hyperMILL*®, you can create transparent processes and intelligent job sequences that will minimise time and effort in both your programming and machining.

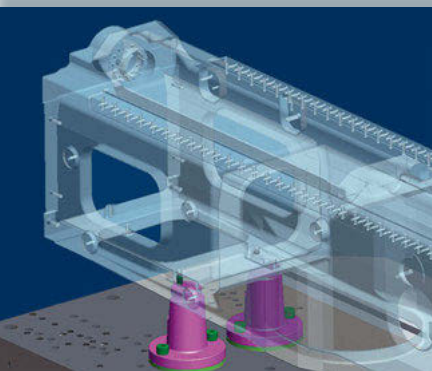

**1 Seamless data importing:**  
Data from PTC Creo, Siemens NX, SOLIDWORKS, CATIA V4® and V5®, and can be imported via a direct software interface. Additionally, you can use the standardised DXF, DWG, STEP, IGES, VDA, STL and Parasolid® interfaces to import data from a wide range of other CAD systems.

**2 Designing and optimising:**  
With *hyperCAD*®, you can design, edit and revise all your 2D and 3D models. The software's intelligent functions let you store, as well as recall, all your user-defined and standard design elements.

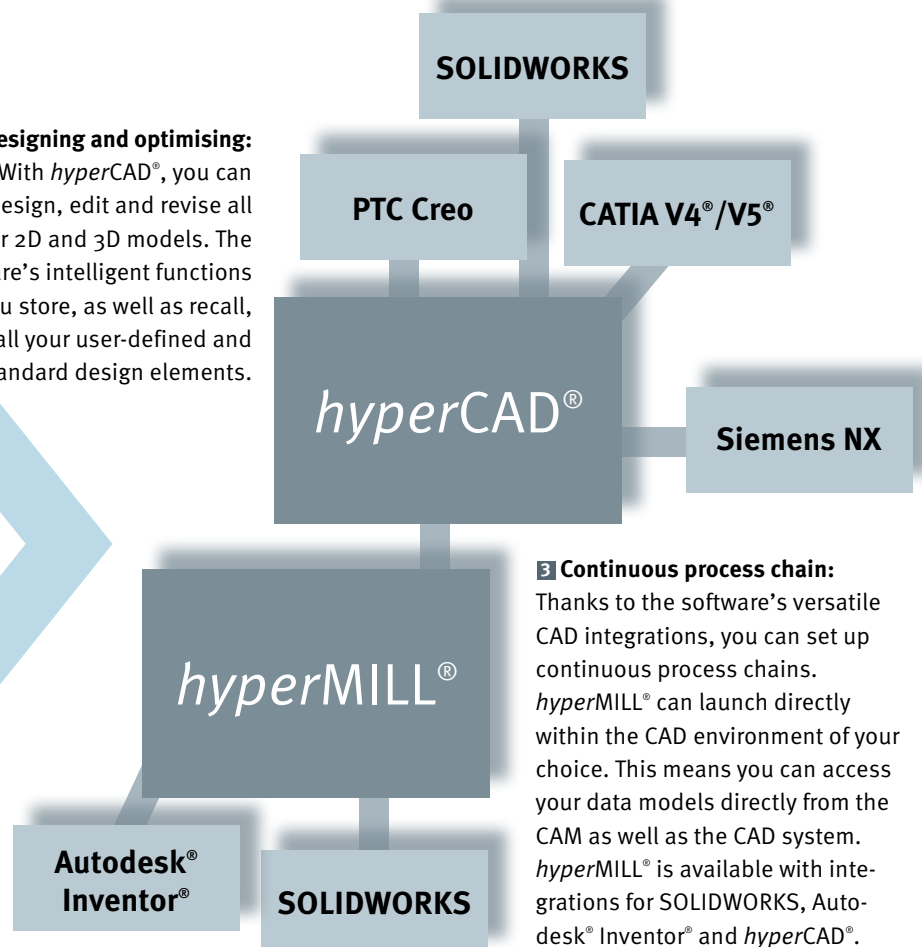

**3 Continuous process chain:**  
Thanks to the software's versatile CAD integrations, you can set up continuous process chains. *hyperMILL*® can launch directly within the CAD environment of your choice. This means you can access your data models directly from the CAM as well as the CAD system. *hyperMILL*® is available with integrations for SOLIDWORKS, Autodesk® Inventor® and *hyperCAD*®.

**7 Simulation with workspace monitoring:** The machine and material removal checks the workspace against a predefined machine model to determine if any limit switches are being traversed by the machining program. The movements of both linear axes (X, Y, Z) and rotary axes (A, B, C) are checked as well.

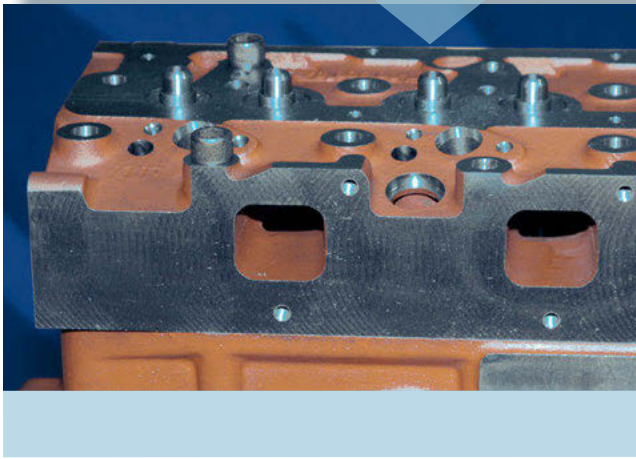
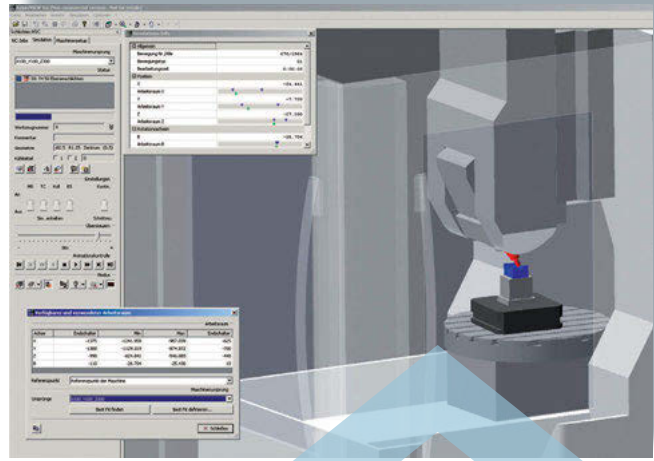

**6 Transparent programming:** *hyperMILL*® provides easy-to-understand job lists. Thanks to a range of sorting functions and bookmarks, you can structure your workflow very clearly. When compiling programs, you can sort the individual processes by job groups, e.g., job steps, geometries or tool positions.

**5 Time-saving programming:** If required, you can work on several projects simultaneously. While *hyperMILL*® is busy calculating one of the projects, you can already be programming the next one. Reduced programming times are further ensured by:

- Access to geometry features in programming
- Database archiving of machining technologies and tools
- Direct replication of individual operations as well as entire job lists

**4 OPEN MIND Tool Database:** The OPEN MIND Tool Database is an easy-to-use management utility for all the tools contained in *hyperMILL*®. Tools are organised systematically by machine, group and individual application. You can store the cutting data for specific tools and material, and calculate them automatically during programming. Holders can be defined individually or complete with tools. Once you have defined a tool or geometry, it is automatically included in collision checking. You can also import tool data directly from the manufacturers' tool definition catalogues.

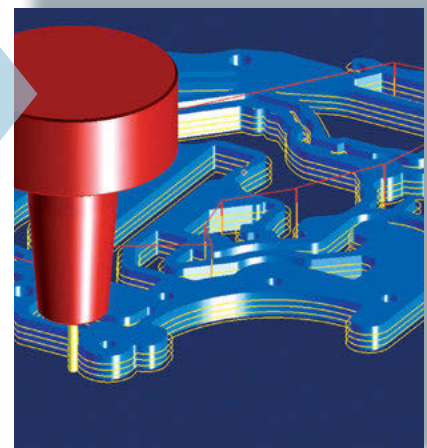



## Fast, yet reliable programming

Geometry features are the basis of any automated programming of different parts with similar characteristics in 2D area. As *hyperMILL*® intelligently stores the machining strategies together with their corresponding tool definitions, you can generate your machining programs nearly automatically.

**Programming with parameters** means you can describe dependencies and make changes associatively to the geometry. As a result, versions and part families can be created very quickly.

**Working with features:** „Features“ are characteristic geometries such as drillings, threads and pockets. These are usually defined in the CAD system, complete with all the relevant machining information. With *hyperMILL*®'s feature recognition functions, you can transport these features directly into the CAM programming environment.

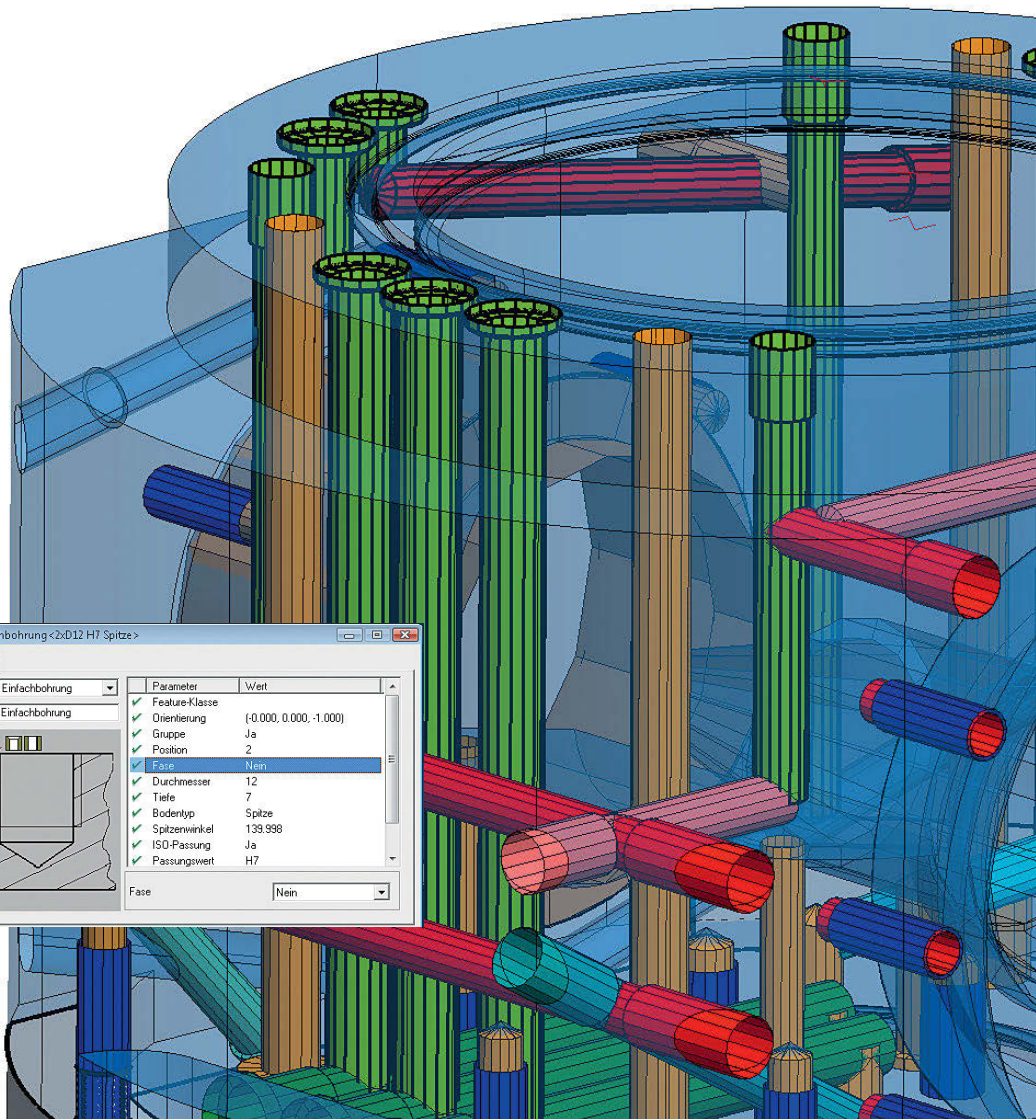
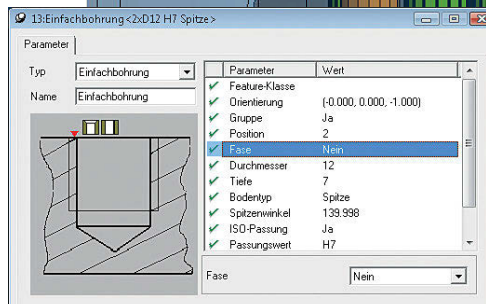



## Feature recognition:

*hyperMILL*®'s automatic feature recognition imports geometry features from solid and surface models. The parameters that are required for programming are generated automatically. The generated features can be grouped automatically or manually according to unique characteristics and work planes. Various filters support the grouping function. You can even group together features with different angles, which greatly simplifies the programming of multi-axis indexing jobs.

**Drilling feature:** You can search your components for holes within a specified range, either with the same orientation and depth, or with a different orientation for multi-axis machining. Drillings can be generated as centred drillings, simple drillings, drillings with chip breaks, or tapings.

**Free drilling feature:** Stepped holes can be programmed very easily with the „Free Drilling“ feature. Within a single feature, different drilling steps and depths can be defined flexibly.

**Pocket feature:** The „Pocket“ feature's recognition function detects closed pockets, pockets with islands and pockets with open sides, and it assigns the correct machining depths. Sorting and grouping occurs automatically based on workplanes and tool angles.

**Multi-axis feature:** *hyperMILL*® can detect geometries and contours, including their position. Workplanes and tool orientation are generated automatically. A multi-axis drilling job is automatically calculated as a 5-axis task with different tool orientations.

**Compounded production expertise:** For characteristic geometries, you can create macros that contain not only the machining strategies but also their respective tool definitions. These macros are stored in the *hyperMILL*® technology database and can be recalled at any time.

**User defined automation:** The Customized Process Features (extended feature technology) allows users to define machining processes and sequences and apply them to the same or similar geometry. This feature enables programming automatically and consistent performance. Operating screens allow a clear definition of the features and the associated parameters.

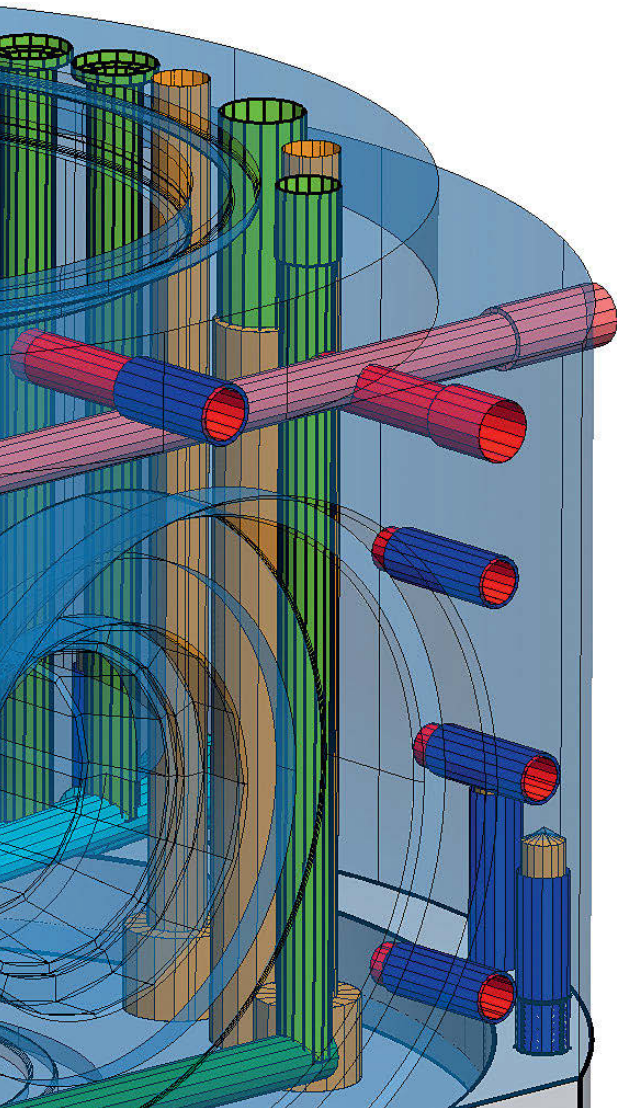
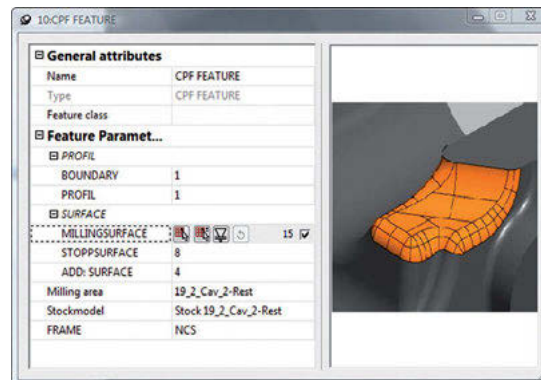
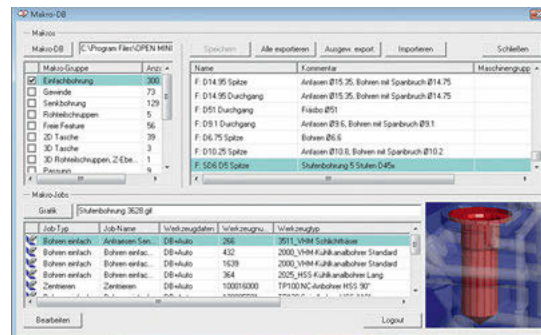
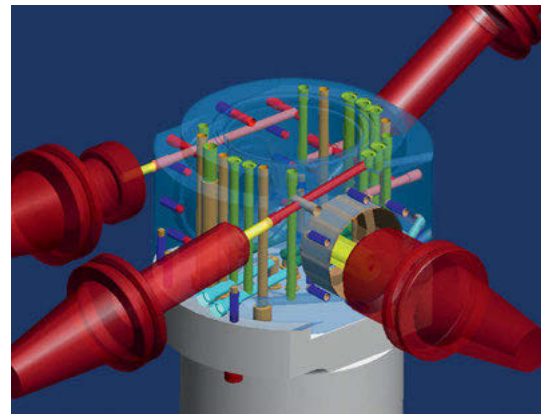
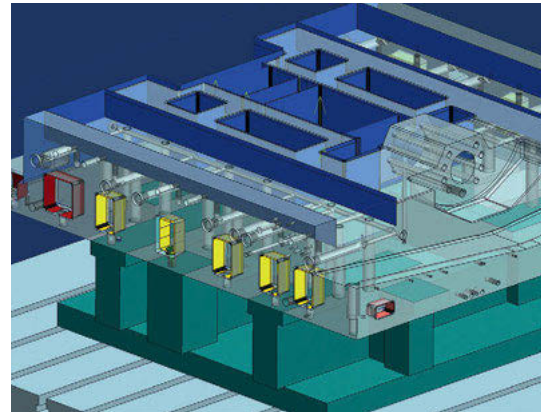
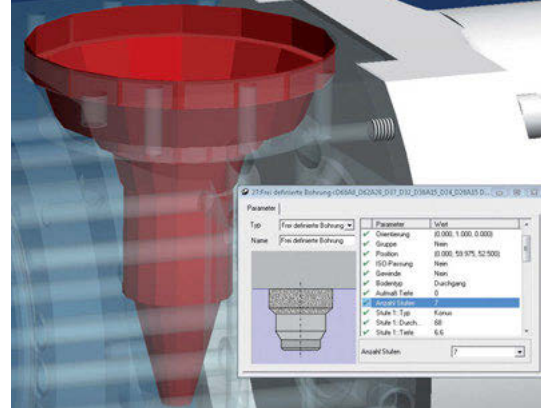

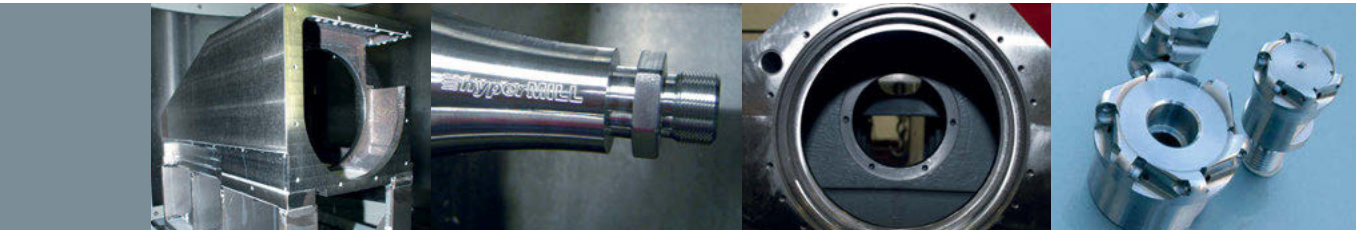

## All strategies under one interface

Whether it's drilling or pocket milling, roughing or finishing, multi-axis indexing, 5-axis machining or mill-turning – *hyperMILL*<sup>®</sup> brings together a superb range of machining strategies and functions within a single user interface. You can programme your parts entirely in just the one CAM system, and machine them in a single setup.

### ***hyperMILL*<sup>®</sup> millTURN:**

This module lets you programme complete machining jobs on mill/turn machines from within a single CAM application. The *millTURN* module is seamlessly integrated with *hyperMILL*<sup>®</sup>:

- All turning and milling cycles can be freely combined.

- Stock tracking is carried out over all turning and milling cycles.
- All turning, milling and drilling tools are managed in a shared database. Cutter and holder geometry can also be defined for turning tools.
- Collision control is carried out during all cycles and through the whole component.
- A postprocessor individually adapted to the machines, controllers and components used generates the NC codes for turning and milling operations.

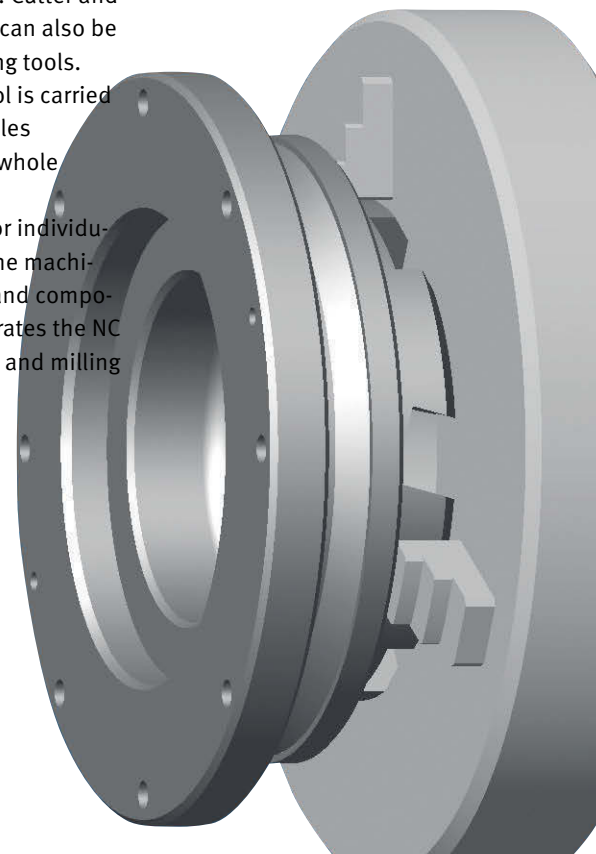
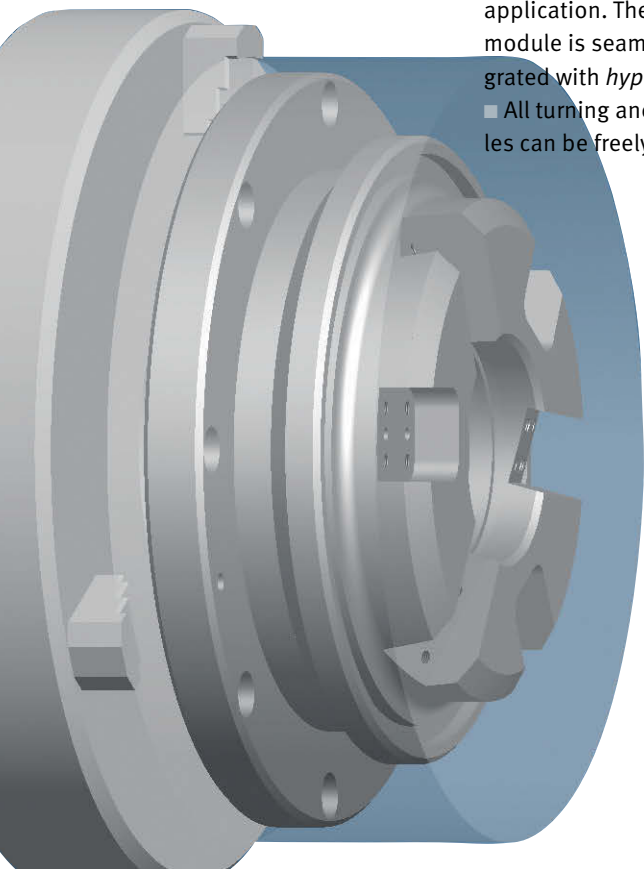

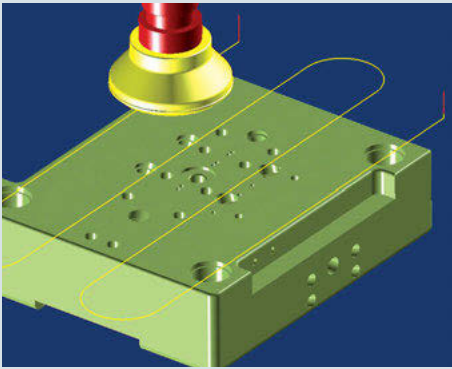

**Face milling:** With the „Face Milling“ strategy, you can machine flat areas quickly and simply in a one-way or zigzag path. This allows several independent surfaces to be machined in a single operation.

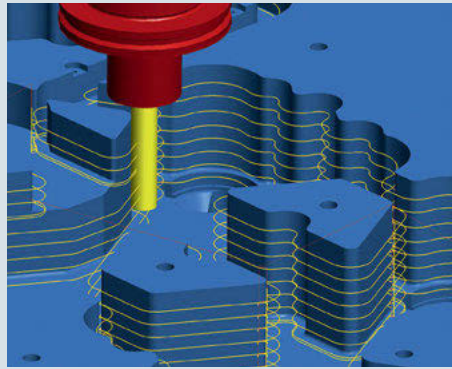

**Contour milling** The „Contour Milling“ strategy is used for machining complex contours. Add-ons and options, such as multiple axial and lateral infeeds, spiral axial stepdown and the definition of infeed points, facilitate the flexible use of this strategy.

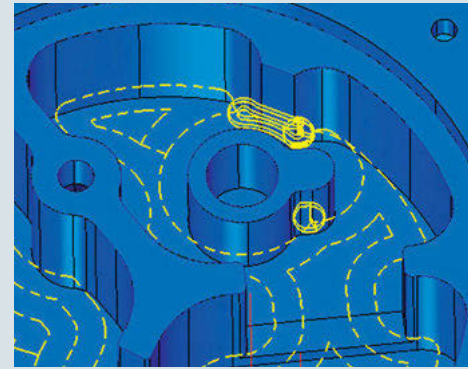

**Pocket Milling** This strategy lets you machine one or multiple pockets, of various sizes and various heights, even if they include islands. The strategy also supports controller cycles for circular and square pockets.

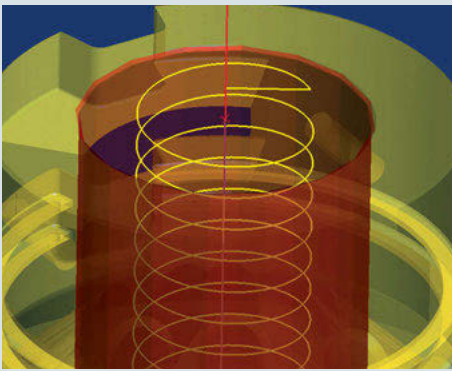

**Helical drilling:** With this strategy, the milling tool cuts into the part in a spiral motion. The user can freely define the pitch of the spiral, within the limits of technological reason. Internal and external threads are produced by thread milling. The „Deep Hole Drilling“ option enables the milling of very deep holes.

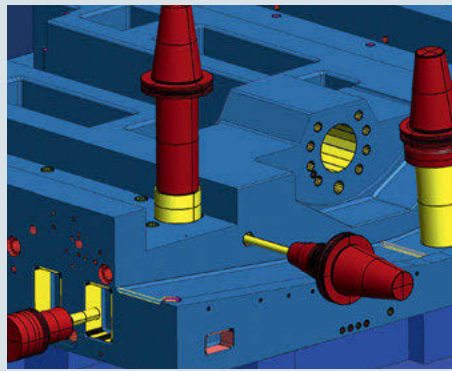

**Multi-axis drilling:** With the „5-Axis Drilling“ function, you can program drill jobs with different tool angles simply and automatically in a single operation. An automated function calculates the tool angle and takes into account all lead-in points to the hole for an assured path.

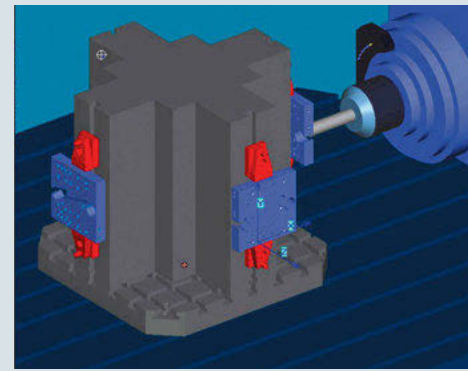

**Multiple clamping:** This function lets you machine parts from different directions without rechucking. Thanks to the part repetition function, parts of programs can be executed multiple times – even with moved and tilted work planes.

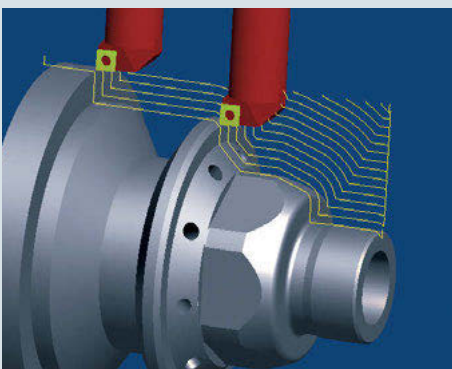

**hyperMILL® millTURN** integrates turning strategies for roughing, finishing, grooving, thread tapping and drilling. Roughing is available as axial, radial and contour-parallel roughing. With finishing, a range of approach and retract macros ensure optimal machining.

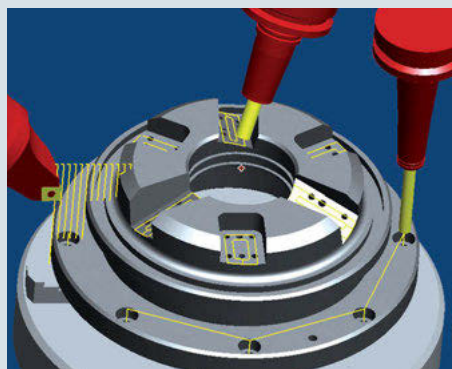

**In everyday programming,** it is an advantage to be able to switch simply and easily between machining strategies for milling and turning. Thanks to the tight integration of the mill/turn module in hyperMILL®, you can directly select the strategy in question (e.g., turn roughing); it is not necessary to open an additional programme.

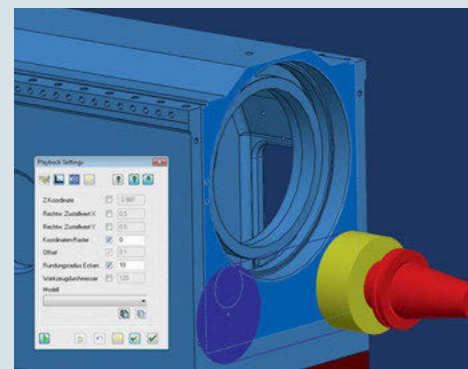

**Playback machining:** Very basic milling operations can easily be programmed using playback machining. Simply enter the required milling diameter and directly generate the milling path by moving the mouse over the respective areas.

- Headquarters** OPEN MIND Technologies AG  
Argelsrieder Feld 5 • 82234 Wessling • Germany  
Phone: +49 8153 933-500  
E-mail: Info.Europe@openmind-tech.com  
Support.Europe@openmind-tech.com
- UK** OPEN MIND Technologies UK Ltd.  
Units 1 and 2 • Bicester Business Park  
Telford Road • Bicester • Oxfordshire OX26 4LN • UK  
Phone: +44 1869 290003  
E-mail: Info.UK@openmind-tech.com
- USA** OPEN MIND Technologies USA, Inc.  
1492 Highland Avenue, Unit 3 • Needham MA 02492 • USA  
Phone: +1 888 516-1232  
E-mail: Info.Americas@openmind-tech.com
- Brazil** OPEN MIND Tecnologia Brasil LTDA  
Av. Andromeda, 885 SL2021  
06473-000 • Alphaville Empresarial  
Barueri • Sao Paulo • Brasil  
Phone: +55 11 2424 8580  
E-mail: Info.Brazil@openmind-tech.com
- Asia Pacific** OPEN MIND Technologies Asia Pacific Pte. Ltd.  
33 Ubi Avenue 3 #06-32 • Vertex (Tower B)  
Singapore 408868 • Singapore  
Phone: +65 6742 95-56  
E-mail: Info.Asia@openmind-tech.com
- China** OPEN MIND Technologies China Co. Ltd.  
Suite 1608 • Zhong Rong International Plaza  
No. 1088 South Pudong Road  
Shanghai 200120 • China  
Phone: +86 21 588765-72  
E-mail: Info.China@openmind-tech.com
- India** OPEN MIND CAD/CAM Technologies India Pvt. Ltd.  
#369/4, 1<sup>st</sup> Floor • 2<sup>nd</sup> Cross • 1<sup>st</sup> 'B' Main Road  
7<sup>th</sup> Block, Jayanagar (W) Bangalore – 560070  
Karnataka • India  
Phone: +91 80 2676 6999  
E-mail: Info.India@openmind-tech.com
- Japan** OPEN MIND Technologies Japan K.K.  
Misumi Bldg. 3F • 1-17-18, Kichijojihigashicho  
Musashino-shi • Tokyo 180-0002 • Japan  
Phone: +81 422 23-5305  
E-mail: info.jp@openmind-tech.co.jp
- Taiwan** OPEN MIND Technologies Taiwan Inc.  
Rm. F, 4F., No.1, Yuandong Rd., Banqiao Dist.  
New Taipei City 22063 • Taiwan  
Phone: +886 2 2957-6898  
E-mail: Info.Taiwan@openmind-tech.com

OPEN MIND Technologies AG is represented worldwide with own subsidiaries and through competent partners and is a member of the Mensch und Maschine technology group, [www.mum.de](http://www.mum.de)



We push machining to the limit

[www.openmind-tech.com](http://www.openmind-tech.com)